

## Bridge Law Information

### Federal Bridge Laws

#### Bridge Gross Weight Formula

Three questions are addressed by this pamphlet with regard to the Bridge Formula: What is it? Why is it necessary? How is it used?

#### What is it?

$$W = 500 \left[ \frac{LN}{N-1} + 12N + 36 \right]$$

$W$  = the maximum weight in pounds that can be carried on a group of two or more axles to the nearest 500 pounds.

$L$  = the distance in feet between the outer axles of any two or more consecutive axles.

$N$  = the number of axles being considered.

This formula limits the weight on groups of axles in order to reduce the risk of damage to highway bridges. Allowable weight depends on the number of axles a vehicle has and the distance between those axles. However, the single- or tandem-axle weight limits supersede the Bridge Formula limits for all axles not more than 96" apart.

#### Why is the Formula Necessary?

Bridges on the Interstate System highways are used by a wide variety of traffic. They are designed to support expected loadings. However, as trucks grew heavier in the 1950s and 1960s, something had to be done to protect bridges. The solution was to tie allowable weights to the number and spacing of axles.

Axle spacing is as important as axle weight in bridge design. A bridge is analogous to thin ice on a pond. Walking on the ice concentrates a person's weight on the small area covered by the individual's feet, and the ice may break. Lying down, however, spreads the same weight over a much larger area, and the ice is less likely to break. Consider trucks crossing a bridge:

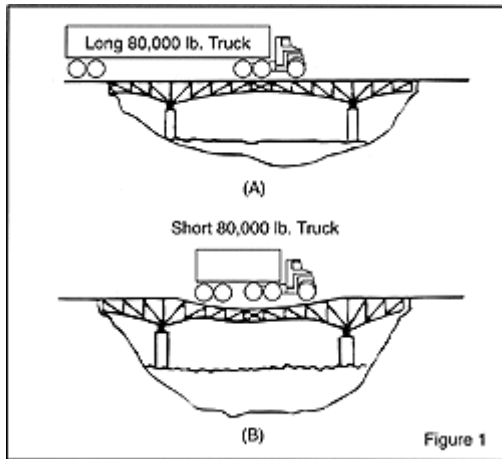

In Figure 1(A), the stress on bridge members as the longer truck rolls across is much less than that caused by the short vehicle in Figure 1(B), even though both trucks have the same total weight and individual axle weights. The weight of the longer vehicle is spread out, while the shorter vehicle has all of the weight concentrated on a small area.

The Federal-Aid Highway Amendments of 1974 increased the weights allowed on the Interstate System to 20,000 lbs. on a single axle, 34,000 lbs. on a tandem axle, and 80,000 lbs. gross weight (23 U.S.C. 127). But Congress balanced this concession to productivity by enacting the Bridge Formula. The result is that motor vehicles may be loaded to the maximum weight only if each group of axles on the vehicle and their spacing also satisfy the requirements of the Formula. This prevents the vehicle from overstressing bridges in the same way that a person lying down on thin ice would minimize the risk of breaking through.

Until 1982, Federal law set only upper limits (or ceilings) on Interstate System weight limits. A few States retained significantly lower weight limits which eventually became barriers to long-distance truck traffic. In 1982, Federal law was amended to make Interstate System weight limits, including the bridge formula limits, both the maximum and the minimum weights (i.e., floors and ceilings) that States must allow on the Interstate System.

### How is the Formula Used?

Some definitions are needed to use the Bridge Formula correctly.

**Gross Weight**—The weight of a vehicle or vehicle combination and any load thereon. The Federal gross weight limit on the Interstate System is 80,000 lbs.

**Single-Axle Weight**—The total weight on one or more axles whose centers are not more than 40" apart. The Federal single-axle weight limit on the Interstate System is 20,000 lbs.

**Tandem-Axle Weight**—The total weight on two or more consecutive axles more than 40" but not more than 96 inches apart. The Federal tandem-axle weight limit on the Interstate System is 34,000 lbs.

Interstate System weight limits in some States may be higher than these figures due to "grandfather" rights. When the Interstate System axle and gross weight limits were adopted in 1956, States were allowed to keep or "grandfather" those which were higher. In 1975, States

were also allowed to keep "grandfathered" bridge formula limits which were higher than those established for the Interstate System.

Bridge Formula calculations yield a series of values usually referred to as Bridge Table B. However, the single-axle weight limit replaces the Bridge Formula weight limit on axles not more than 40" apart, and the tandem-axle weight limit replaces the Bridge Formula weight limit for axles over 40 but not more than 96 inches apart. At 97" apart, two axles can carry 38,000 lbs. and three axles 42,000 lbs., as shown in Figure 2.

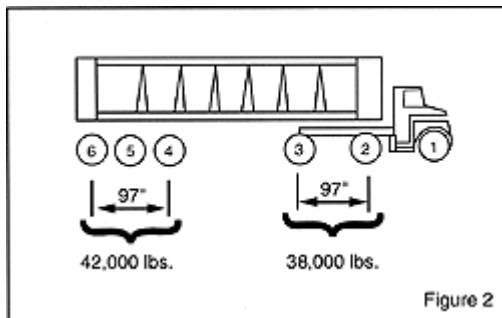

Federal law provides that any two or more consecutive axles may not exceed the weight computed by the Formula even though single axles, tandem axles, and gross weight are within legal limits. In other words, the axle group that includes the entire truck—sometimes call the "outer bridge" group—must comply with the Bridge Formula. But interior combinations of axles, such as the "tractor bridge" (axles 1, 2, and 3) and "trailer bridge" (axles 2, 3, 4, and 5), must also be in compliance with weights computed by the Formula (Figure 3).

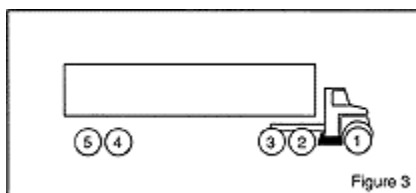

The most common vehicle checked for compliance with weight limit requirements is shown in Figure 3. While the Bridge Formula applies to each combination of two or more axles, experience shows that axle combinations 1 through 3, 1 through 5, and 2 through 5 are critical and must be checked. If these combinations are found to be satisfactory, all of the others on this type of vehicle will normally be satisfactory.

The vehicle with weights and axle dimensions as shown in Figure 4 will be used to illustrate a Bridge Formula check.

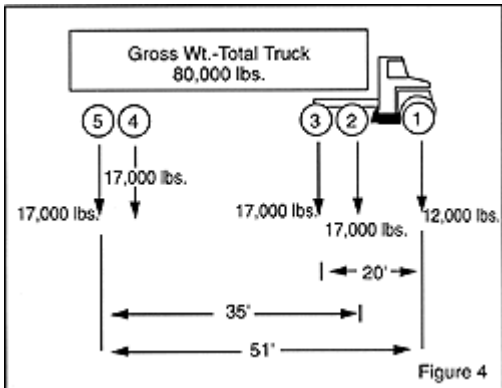

Before checking a vehicle for compliance with the Bridge Formula, its single-axle, tandem-axle, and gross weight should be checked. Here the single axle (number 1) does not exceed 20,000 lbs., tandems 2-3 and 4-5 do not exceed 34,000 lbs. each, and the gross weight does not exceed 80,000 lbs. These preliminary requirements are thus satisfied. The first Bridge Formula combination is checked as follows:

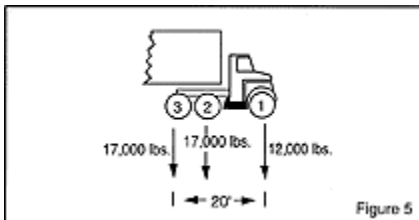

### Check of 1 thru 3 (Figure 5)

Actual weight = 12,000 + 17,000 + 17,000 = 46,000 lbs.

N = 3 axles

L = 20 ft

$$W = 500 \left( \frac{LN}{N-1} + 12N + 36 \right)$$

$$W = 500 \left[ \frac{(20 \times 3)}{(3-1)} + (12 \times 3) + 36 \right]$$

W maximum = 51,000 lbs., which is more than the actual weight of 46,000 lbs., so the Bridge Formula requirement is satisfied.

### Example—Bridge Table B

This same number (51,000 lbs.) could have been obtained from Bridge Table B as shown by reading down the left side to L = 20 and across to the right where N = 3.

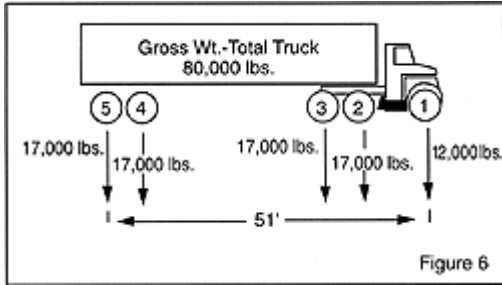

**Now check axles 1 thru 5 (Figure 6)**

Actual weight = 12,000 + 17,000 + 17,000 + 17,000 + 17,000 = 80,000 lbs.

W maximum, from Table B for "L" of 51 feet and "N" of 5 = 80,000 lbs.

Therefore, this axle spacing is satisfactory.

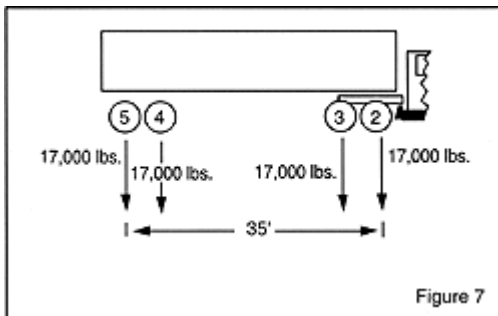

**Now check axles 2 thru 5 (Figure 7)**

Actual weight = 17,000 + 17,000 + 17,000 + 17,000 = 68,000 lbs.

W maximum, from Table B for "L" of 35 feet and "N" of 4 = 65,500 lbs.

This is a violation because the actual weight exceeds the weight allowed by the Bridge Formula. To correct the situation, some load must be removed from the vehicle or the axle spacing (35

## Permissible Gross Loads For Vehicles In Regular Operation<sup>1</sup>

$$W = 500 \left[ \frac{LN}{N-1} + 12N + 36 \right]$$

Based on weight formula

Distance in feet (L) between the extremes of any group of 2 or more consecutive axles	<b>[Bridge Table B]</b> Maximum load in pounds carried on any group of 2 or more consecutive axles <sup>2</sup>								
	<b>N =</b>	<b>2 AXLES</b>	<b>3 AXLES</b>	<b>4 AXLES</b>	<b>5 AXLES</b>	<b>6 AXLES</b>	<b>7 AXLES</b>	<b>8 AXLES</b>	<b>9 AXLES</b>
4		34,000							
5		34,000							
6		34,000							
7		34,000							
8 & less		34,000	34,000						
more than 8		38,000	42,000						
9		39,000	42,500						
10		40,000	43,500						
11			44,000						
12			45,000	50,000					
13			45,500	50,500					
14			46,500	51,500					
15			47,000	52,000					
16			48,000	52,500	58,000				
17			48,500	53,500	58,500				
18			49,500	54,000	59,000				
19			50,000	54,500	60,000				
20			51,000	55,500	60,500	66,000			
21			51,500	56,000	61,000	66,500			
22			52,500	56,500	61,500	67,000			
23			53,000	57,500	62,500	68,000			
24			54,000	58,000	63,000	68,500	74,000		
25			54,500	58,500	63,500	69,000	74,500		
26			55,500	59,500	64,000	69,500	75,000		
27			56,000	60,000	65,000	70,000	75,500		
28			57,000	60,500	65,500	71,000	76,500	82,000	
29			57,500	61,500	66,000	71,500	77,000	82,500	
30			58,500	62,000	66,500	72,000	77,500	83,000	
31			59,000	62,500	67,500	72,500	78,000	83,500	

32		60,000	63,500	68,000	73,000	78,500	84,500	90,000
33			64,000	68,500	74,000	79,000	85,000	90,500
34			64,500	69,000	74,500	80,000	85,500	91,000
35			65,500	70,000	75,000	80,500	86,000	91,500
36			66,000	70,500	75,500	81,000	86,500	92,000
37			66,500	71,000	76,000	81,500	87,000	93,000
38			67,500	71,500	77,000	82,000	87,500	93,500
39			68,000	72,500	77,500	82,500	88,500	94,000
40			68,500	73,000	78,000	83,500	89,000	94,500
41			69,500	73,500	78,500	84,000	89,500	95,000
42			70,000	74,000	79,000	84,500	90,000	95,500
43			70,500	75,000	80,000	85,000	90,500	96,000
44			71,500	75,500	80,500	85,500	91,000	96,500
45			72,000	76,000	81,000	86,000	91,500	97,500
46			72,500	76,500	81,500	87,000	92,500	98,000
47			73,500	77,500	82,000	87,500	93,000	98,500
48			74,000	78,000	83,000	88,000	93,500	99,000
49			74,500	78,500	83,500	88,500	94,000	99,500
50			75,500	79,000	84,000	89,000	94,500	100,000
51			76,000	80,000	84,500	89,500	95,000	100,500
52			76,500	80,500	85,000	90,500	95,500	101,000
53			77,500	81,000	86,000	91,000	96,500	102,000
54			78,000	81,500	86,500	91,500	97,000	102,500
55			78,500	82,500	87,000	92,000	97,500	103,000
56			79,500	83,000	87,500	92,500	98,000	103,500
57			80,000	83,500	88,000	93,000	98,500	104,000
58				84,000	89,000	94,000	99,000	104,500
59				85,000	89,500	94,500	99,500	105,000
60				85,500	90,000	95,000	100,500	105,500

<sup>1</sup>The permissible loads are computed to the nearest 500 pounds as required by statute.

<sup>2</sup>The following loaded vehicles must not operate over H15-44 bridges: 3-S2 (5-axle) with wheelbase less than 38 feet; 2-S1-2 (5-axle) with wheelbase less than 45 feet; 3-3 (6-axle) with wheelbase less than 45 feet; and 7-, 8- and 9-axle vehicles regardless of wheelbase.

Tandem Axle Weight (See pages <a href="#">4</a> & <a href="#">5</a> )
Within Interstate Gross Weight Limit
Exception

## State Contacts

	Overweight/ Oversize Permits	Interstate 80,000 lbs. unless otherwise stated	State Highway	State Maximum
Alabama	(334) 834-1092		> B	84,000 on 6 axles
Alaska	(907) 345-7636	Exempt from interstate weight regulation		Up to 145,000 on 11 axles
Arizona	(602) 255-7346	LCV	B	80,000
Arkansas	(501) 569-2381		B	80,000
California	(916) 654-4828		B	80,000
Colorado	(303) 757-9539	LCV	> B	85,000
Connecticut	(860) 594-2880		> B	80,000
Delaware	(302) 739-4374		< B	80,000 on 5 axles
Dist. of Columbia	(202) 727-7050		> B	80,000
Florida	(904) 488-4961		> B	80,000
Georgia	(404) 656-5435		> B	80,000
Hawaii	(808) 587-2185		> B	88,000
Idaha	(208) 334-8420	LCV	> B	105,500 on 6 axles
Illinois	(217) 785-1477		< B	73,280 non-NN highway
Indiana	(317) 486-5500	LCV	B	80,000
Iowa	(515) 237-3264		B	80,000
Kansas	(913) 266-2040	LCV	B	85,500
Kentucky	(502) 564-7150		B	80,000
Louisiana	(504) 343-2345		> B	88,000 Tri or Quad axle
Maine	(207) 287-8632		> B	90,000
Maryland	(410) 787-4088		> B	80,000
Massachusetts	(508) 624-0819		> B	80,000
Michigan	(517) 373-2120		> B	164,000 on 11 axles
Minnesota	(612) 405-6000		< B	80,000 on 6 axles
Mississippi	(601) 359-1148		B	80,000 (57,650 on highway class)
Missouri	(573) 751-2871	LCV	< B	73,280 (2,000 tolerance)
Montana	(406) 444-6130	LCV	B	80,000
Nebraska	(402) 479-4775		B	95,000 on 7 axles
Nevada	(702) 687-5410	LCV	B	Uncapped
New Hampshire	(603) 271-2691		> B	80,000
New Jersey	(908) 247-0900		B	80,000



New Mexico	(505) 827-0383		> B	86,400
New York	(518) 457-1155		> B	80,000
North Carolina	(919) 574-6683		> B	80,000
North Dakota	(701) 328-2621		LCV > B	105,500 on 7 axles
Ohio	(614) 777-0224		LCV B	80,000
Oklahoma	(405) 425-2390		LCV B	90,000
Oregon	(503) 945-7903		LCV B	80,000
Pennsylvania	(717) 787-5367		> B	80,000
	(401) 277-2986 (overweight), (401) 277-3175 (oversize)		> B	80,000
Rhode Island			> B	80,000
South Carolina	(803) 737-1279		> B	80,000
South Dakota	(605) 773-4578		LCV B	Uncapped
Tennessee	(615) 741-3821		B	80,000
Texas	(800) 299-1700		B	80,000
Utah	(801) 965-4508		LCV B	80,000
Vermont	(802) 828-2070		B	80,000
Virginia	(804) 786-2787		B	80,000
Washington	(206) 753-6554		B	80,000
West Virginia	(304) 348-0384		< B	65,000 (73,500 some highways)
Wisconsin	(608) 266-7320		B	80,000
Wyoming	(307) 777-4376		> B	117,000 on 8 axles

LCV = Longer Combination Vehicle

### Exception to Formula and Table B

Federal law (23 U.S.C. 127) includes one exception to the Bridge Formula and Table B—two consecutive sets of tandem axles may carry 34,000 lbs. each if the overall distance between the first and last axles of these tandems is 36 feet or more. For example, a five-axle tractor-semitrailer combination may carry 34,000 lbs. both on the tractor tandem (axles 2 and 3) and the trailer tandem (axles 4 and 5), provided axles 2 and 5 are spaced at least 36 feet apart. Without this exception, the Bridge Formula would allow an actual weight of only 66,000 and 67,500 lbs. on tandems spaced 36 to 38 feet apart.

### Bridge Formula Application to Single Unit Trucks

The procedure described above can be used to check any axle combinations, but several closely spaced axles usually produce the most critical situation.

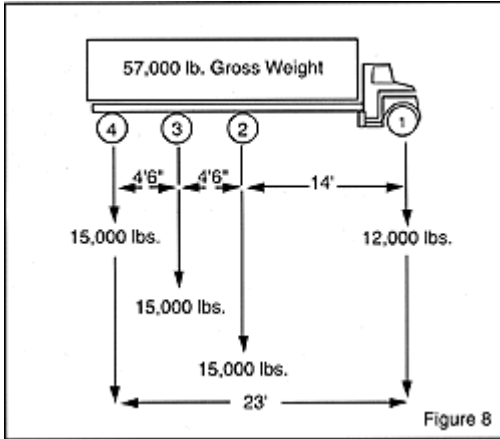

The truck in Figure 8 satisfies the single axle weight limit (12,000 lbs. is less than 20,000 lbs.), the tandem axle limit (30,000 lbs. is less than 34,000 lbs.) and gross weight limit (57,000 lbs. is less than 80,000 lbs.). With these restrictions satisfied, a check will be made for Bridge Formula requirements, axles 1 through 4.

Actual weight = 12,000 + 15,000 + 15,000 + 15,000 = 57,000 lbs.

W maximum for "N" of 4 and "L" of 23 feet = 57,500 (From Table B).

Since axles 1 thru 4 are satisfactory, check axles 2 thru 4:

W (actual) = 15,000 + 15,000 + 15,000 = 45,000 lbs.

W maximum for "N" of 3 and "L" of 9 feet = 42,500 lbs. (From Table B).

This is a violation. The load would have to be reduced, axles added, or spacing increased, to comply with the Bridge Formula.

### Caution

This pamphlet paraphrases the actual provisions in 23 U.S.C. 127 and 23 CFR 658 for the sake of clarity. In case of a dispute, the statute and regulations will govern.

Previous editions of this pamphlet released under the title "Bridge Gross Weight Formula," dated April 1984, remain valid. Neither the Formula nor any resulting maximum gross weight values (table entries) have been changed.